

# CRANE SCALES with Heat Insulating Shield & Wireless Indicator (CCS)

## 200g to 15ton

### Features :

- ♦ Heavy duty aluminum diecast enclosure.
- ♦ Special construction for high temperature shielding.
- ♦ Minimum distance for normal operation is 2 mtr from a heat radiation source at 1500° C.
- ♦ Wireless transmission maximum operating distance between the Scale and Indicator is 50 mtr.
- ♦ All specifications are same as standard crane scales with heat insulating shield(CCS) except there is no display on the scale and there is no remote keyboard.
- ♦ Power indication LED on the scale.
- ♦ Battery & charger for the loadcell & transmitter inside the scale.
- ♦ Weight display on the desktop indicator along with controls.
- ♦ RS-232 interface in the indicator.
- ♦ Storage of weights in memory upto 100 samples.

(1, 2, 3, 5, 10, 15 ton)

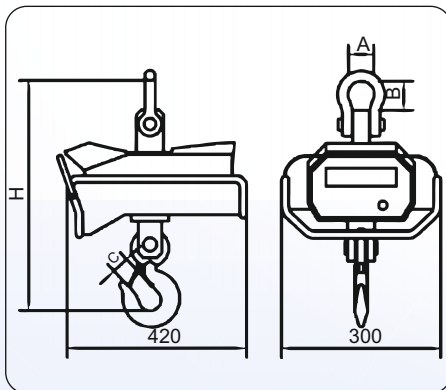
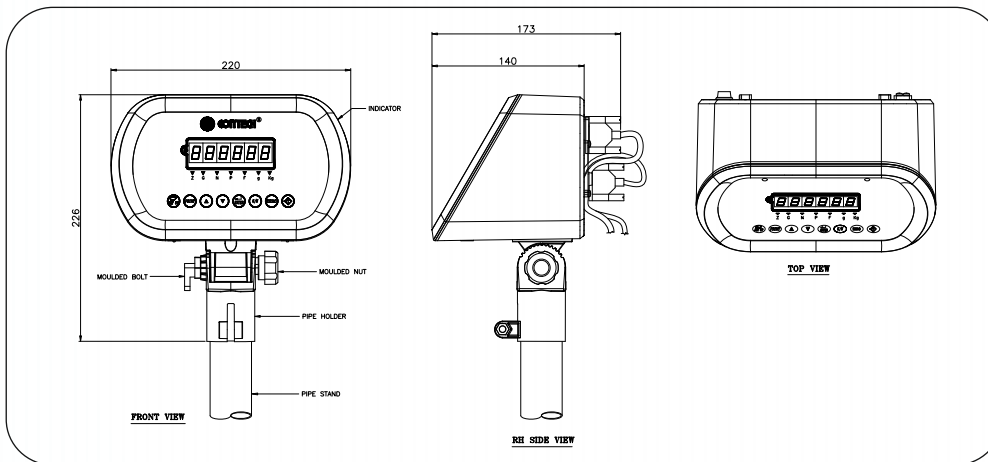

### Common Specifications :

MODELS	CAPACITY	ACCURACY	DIMENSION				NET WT. (Kg)
			H	A	B	C	
CCS-1T200	1 ton	200g	465	56	65	25	26
CCS-2T500	2 ton	500g	490	56	65	32	30
CCS--3T1K	3 ton	1Kg	570	72	90	36	36
CCS-5T2K	5 ton	2Kg	640	90	110	50	42
CCS-10T5K	10 ton	5Kg	920	140	230	60	77
CCS-15T5K	15 ton	5Kg	980	140	230	70	85

Taring Range : Up to full capacity

Response time : 5 seconds

Power Req : 90-250V, 50/60Hz, 10 Watt

Operating Temperature : 10 to 45 deg C



301, Punit Indl. Premises, Turbhe Naka, Navi Mumbai - 400 705.

Tel. : +91 22 6139 3000 (100 lines)

E-mail : sales@contechindia.in

Website : www.contechindia.com



Plot No. EL-221 TTC Indl. Area, MIDC (Electronic Zone), Mhape, Navi Mumbai - 400 710.

### Impeccable Credentials

